

NHN-TC2B40

CPU Special Terminal Block
CPU专用端子台



产品特点 FEATURES

- 采用40P的MIL连接器作为进线端，可以直接对应MITSUBISHI Q系列PLC输入输出模块；
- PLC与端子台之间为1对1连接，不需专用连接线，每个信号位均带有LED状态指示，让使用者一目了然，使配线工作变得更轻松；
- 小型化设计，使配线箱更整洁。
- Utilized 40P MIL connector as input port, which can directly corresponding to input/output module of Mitsubishi Q PLC.
- Through point to point connect with PLC and terminal blocks and no need any special connect lines Each signal takes along with LED lights to make wiring easier and visible;
- Miniaturization design Neat wiring cabinet

注意事项 Note

- 订购前请确认负载类型和大小，选择使用合适方式进行控制。
- 和PLC连接时，请勿必使用本公司开发的与之对应的专用电缆线。
- Before ordering, please confirm the load type and size, choose the suitable way to control.
- When PLC connection, please be sure to use the company developed and the corresponding special cable.

关联产品 RELATED PRODUCTS

适用电缆 Suitable cable X210-5

适合电线 SUITABLE WIRE

剥线长度: 6mm 1.5mm² Following /AWG16



适用PLC SUITABLE PLC

MITSUBISHI

NPN:L02CPU
L26CPU-BT

PNP:L02CPU-P
L26CPU-PBT

外形尺寸图 DIMENSIONS

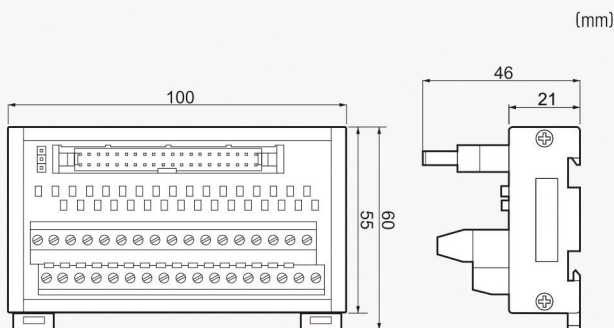

注意事项 Note:

- 可安装在标准35mm的DIN导轨上
- DIN Rail Mounting: Standard 35mm DIN RAIL.

接线图 WIRING DIAGRAM

